



ACEAIR®



Flange Ends

2/2-way stainless steel Angle Seat Valve with big flow capacity, Pneumatically Operated, Excellent seat tightness due to PTFE soft sealing, for Medium up to +180°C, Port connection DN 15-100.

Angle Seat Valve(Piston Valve) Series PV400 (Flange Ends)

2/2-way Angle-Seat Valve Pneumatically Operated, for medium up to +180° C, with Flange ends port connection DN 15 - 100

- High flow rate;
- Long life cycle;
- NC and NO universal actuators with modular universal accessory program up to control heads;
- Deliverable with flow direction below or above seat
- Simple conversion of the circuit function.

◆ How to Order



PV400 P 015 NC S x 63mm

Acting type

S	Single acting	D	Double acting
---	---------------	---	---------------

Body Material

Blank	S.S 304 (standard)
4	S.S 316
5	S.S 316L

Type of actuation

NO	Normally Open
NC	Normally Closed (standard)

Nominal diameter

		15	G1/2
20	G3/4	25	G1
32	G1 1/4	40	G1 1/2
50	G2	65	G2 1/2
80	G3	100	G4

Actuator Material code

P	Plastic Actuator
S	S.S. Actuator
A	Aluminium Actuator

Model

PV400	400 series Angle Seat Valve
-------	-----------------------------

Symbol **Control function A**
(closed by spring force
in rest position)

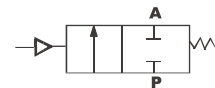

Control function B
(open in rest position)

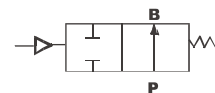

Control function I
(double-acting actuator)

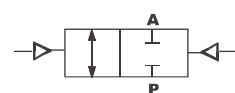

◆ Actuator Size

Port Size	Standard Actuator Size mm		
	PA	S.S.	AL
DN10	40,50	40,50	40,50
DN15	40,50	40,50	40,50
DN20	50,63,80	50,63,90	50,63,80
DN25	50,63,80	50,63,90	50,63,80
DN32	63,80	63,90	63,80
DN40	63,80	63,90	63,80
DN50	63,80	63,90	63,80
DN65	80,100	90,125	80,100
DN80	100	125	100
DN100	125	125	125

◆ Flange Specification DIN2576(GB/T82.1)

- ◆ PV400 Series Plunger Pilot angle seat valve is propelled by a piston actuator, either single acting or double acting. Actuators are made of three different materials, applicable to different working temperature:

2/2 Way stainless steel valve with big flow capacity

V type seals ensure reliable and effective sealing

Maintenance free, compatible with various accessories,

Direction indicating, stroke limiting or manual switching

can be achieved conveniently.

Angle Seat Valve(Piston Valve) Series PV400 (Flange Ends)



◆ Pressure Data Sheet

Control function	Acting type	Flow Direction	Water Hammer	Application
Normally Closed	Single Acting	Upstream	Yes	For compressible medium (such as gas and steam) and liquid of comparatively low pressure
		Downstream	No	For anti water hammer pipeline, bears certain pressure difference
	Double Acting	Upstream	Yes	Reliable performance, bears pressure difference; valve closes automatically in case of an emergency.
		Downstream	No	For pipeline required of better anti water hammer, bears big pressure difference
Normally Open		Upstream	Yes	For pipeline where valve keeps open, double acting & normally open when silencer comes off.
		Downstream	No	For pipeline where valve keeps open, anti water hammer, double acting & normally open when silencer comes off

Water hammer (or, more generally, fluid hammer) is a pressure surge or wave caused when a fluid (usually a liquid but sometimes also a gas) in motion is forced to stop or change direction suddenly (momentum change). A water hammer commonly occurs when a valve closes suddenly at an end of a pipeline system, and a pressure wave propagates in the pipe. It is also called hydraulic shock. This pressure wave can cause major problems, from noise and vibration to pipe collapse. It is possible to reduce the effects of the water hammer pulses with accumulators, expansion tanks, surge tanks, and other features.

Designed to close againstflow. Will not chatter or produce water hammer . Operates smoothly and quietly.

Port Size	DN (mm)	Actuator (mm)	Single Acting Normally Closed				Double Acting Normally Closed				Normally Open				Double Acting Assistant Pressure	Rest Position Pressure Mpa		
			Upstream		Downstream		Upstream		Downstream		Upstream		Downstream					
			Press. Range	Control Press.	Press. Range	Control Press.	Press. Range	Control Press.	Press. Range	Control Press.	Press. Range	Control Press.	Press. Range	Control Press.				
1/2"	DN15	40	0~1.6	0.3~0.45	0~1.1	0.3	0~1.6	0.3~0.45	0~1.6	0.3~0.35	0~1.6	≥ 0.3	0~1.6	0~1.6	0~1.6	0.2~0.4	≥ 0.4	0~0.2
		50	0~1.6	0.3~0.35	0~1.4	0.45	0~1.6	0.3~0.35	0~1.6	0.3~0.35	0~1.6	≥ 0.3	0~1.6	0~1.6	0~1.6	0.2~0.4	≥ 0.4	0~0.1
3/4"	DN20	50	0~1.6	0.3~0.4	0~1.4	0.45	0~1.6	0.3~0.4	0~1.6	0.3~0.4	0~1.6	≥ 0.3	0~1.6	0~1.2	0~1.6	0.3~0.65	0.3~0.4	0~0.2
		63	0~1.6	0.3~0.38	0~1.4	0.45	0~1.6	0.3~0.38	0~1.6	0.3~0.38	0~1.6	0.3~0.5	0~1.6	0~1.4	0~1.6	0.35~0.7	0.3~0.35	0~0.35
		80	0~1.6	0.2~0.35	0~1.4	0.4	0~1.6	0.2~0.35	0~1.6	0.3~0.4	0~1.6	0.3~0.4	0~1.6	0~1.4	0~1.6	0.35~0.7	0.3~0.4	0~0.5
		90 SS	0~1.6	0.2~0.3	0~1.4	0.35	0~1.6	0.2~0.3	0~1.6	0.3~0.4	0~1.6	0.3~0.4	0~1.6	0~1.6	0~1.6	0.35~0.7	0.3~0.4	0~0.4
1"	DN25	50	0~1.6	0.3~0.45	0~0.75	0.45	0~1.6	0.3~0.45	0~1.3	0.3~0.6	0~1.6	0~0.3	0~1.3	0.3~0.6	0.3~0.4	0.3~0.4	0~0.35	
		63	0~1.6	0.3~0.35	0~1.4	0.5	0~1.6	0.3~0.35	0~1.6	0.3~0.4	0~1.6	0~1.6	0~1.6	0.35~0.6	0.3~0.55	0~0.35		
		80	0~1.6	0.2~0.3	0~1.4	0.45	0~1.6	0.2~0.3	0~1.6	0.3~0.4	0~1.6	0~1.6	0~1.6	0.35~0.6	0.35~0.55	0~0.5		
		90 SS	0~1.6	0.2~0.25	0~1.4	0.4	0~1.6	0.2~0.25	0~1.6	0.2~0.3	0~1.6	0.2~0.3	0~1.6	0~1.6	0.35~0.6	0.35~0.55	0~0.4	
1-1/4"	DN32	63	0~1.6	0.3~0.5	0~0.06	0.5	0~1.4	0.3~0.5	0~1.4	0.3~0.6	0~1.6	0~1.4	0~1.3	0.35~0.7	0.3~0.5	0~0.4		
		80	0~1.6	0.2~0.45	0~1.4	0.6	0~1.6	0.2~0.45	0~1.6	0.3~0.5	0~1.6	0~1.6	0~1.6	0.35~0.7	0.3~0.55	0~0.5		
		90 SS	0~1.6	0.2~0.35	0~1.6	0.65	0~1.6	0.2~0.35	0~1.6	0.2~0.4	0~1.6	0~1.6	0~1.6	0.35~0.7	0.3~0.55	0~0.4		
1-1/2"	DN40	63	0~1.6	0.3~0.6	0~0.05	0.5	0~1.1	0.3~0.6	0~1.3	0.3~0.7	0~1.6	0~1.4	0~0.65	0.35~0.7	0.3~0.6	0~0.4		
		80	0~1.6	0.3~0.55	0~1.4	0.6	0~1.6	0.3~0.55	0~1.6	0.3~0.6	0~1.6	0~1.6	0~1.6	0.35~0.7	0.3~0.7	0~0.5		
		90 SS	0~1.6	0.2~0.35	0~1.6	0.65	0~1.6	0.2~0.35	0~1.6	0.2~0.6	0~1.6	0~1.6	0~1.6	0.35~0.7	0.3~0.7	0~0.5		
2"	DN50	63	0~1.0	0.3~0.65	0~0.35	0.5	0~0.9	0.3~0.65	0~0.8	0.35~0.8	0~1.0	0~0.6	0~0.5	0.35~0.7	0.35~0.7	0~0.8		
		80	0~1.6	0.3~0.55	0~0.9	0.65	0~1.6	0.3~0.55	0~1.6	0.3~0.7	0~1.6	0~1.0	0~0.6	0.35~0.7	0.35~0.7	0~0.5		
		90 SS	0~1.6	0.3~0.5	0~1.1	0.65	0~1.6	0.3~0.5	0~1.6	0.3~0.6	0~1.6	0~1.0	0~1.2	0.35~0.7	0.35~0.7	0~0.4		
		100	0~1.6	0.25~0.4	0~1.4	0.65	0~1.6	0.25~0.4	0~1.6	0.3~0.6	0~1.6	0~1.4	0~1.4	0.35~0.7	0.35~0.7	0~0.4		
		125 SS	0~1.6	0.2~0.3	0~1.6	0.65	0~1.6	0.2~0.3	0~1.6	0.3~0.4	0~1.6	0~1.4	0~1.4	0.35~0.7	0.35~0.7	0~0.5		
2-1/2"	DN65	80	0~1.6	0.3~0.65	0~0.5	0.65	0~1.6	0.3~0.65	0~1.1	0.3~0.7	0~1.6	0~0.5	0~0.75	0.3~0.65	0.35~0.7	0~0.5		
		90 SS	0~1.6	0.2~0.6	0~0.7	0.65	0~1.6	0.2~0.6	0~1.6	0.3~0.7	0~1.6	0~1.0	0~1.4	0.3~0.6	0.35~0.7	0~0.4		
		100	0~1.6	0.3~0.45	0~0.8	0.65	0~1.6	0.3~0.45	0~1.6	0.3~0.55	0~1.6	0~1.0	0~0.8	0.35~0.7	0.35~0.7	0~0.4		
		125 SS	0~1.6	0.2~0.7	0~0.9	0.65	0~1.6	0.2~0.7	0~1.6	0.2~0.55	0~1.6	0~1.4	0~1.4	0.3~0.7	0.35~0.7	0~0.5		
3"	DN80	100	0~1.6	0.35~0.6	0~0.5	0.65	0~1.6	0.35~0.6	0~1.6	0.3~0.55	0~1.6	0~0.6	0~0.75	0.35~0.7	0.35~0.7	0~0.4		
		125 SS	0~1.6	0.2~0.7	0~0.6	0.65	0~1.6	0.2~0.7	0~1.6	0.3~0.65	0~1.6	0~0.7	0~1.2	0.35~0.7	0.35~0.7	0~0.5		
4"	DN100	125	0~1.6	0.2~0.7	0~0.6	0.65	0~1.6	0.2~0.7	0~1.6	0.3~0.65	0~1.6	0~0.7	0~1.2	0.35~0.7	0.35~0.7	0~0.5		
		125 SS	0~1.6	0.2~0.7	0~0.6	0.65	0~1.6	0.2~0.7	0~1.6	0.3~0.65	0~1.6	0~0.7	0~1.2	0.35~0.7	0.35~0.7	0~0.5		

Model Specification	Normally Closed	P015NC	P020NC	P025NC	P032NC	P040NC	P050NC	P065NC	P080NC	P100NC
	Normally Open	P015NO	P020NO	P025NO	P032NO	P040NO	P050NO	P065NO	P080NO	P100NO
	Normally Closed	S015NC	S020NC	S025NC	S032NC	S040NC	S050NC	S065NC	S080NC	S100NC
	Normally Open	S015NO	S020NO	S025NO	S032NO	S040NO	S050NO	S065NO	S080NO	S100NO

Material of Body / Actuator	S.S304 316 /PA									
Seat seal	PTFE/FPM									
Stem seal	PTFE/FPM									
Piston Seal	PTFE/FPM									
Temperature of Medium	PTFE	- 10 ~200℃								
	FPM	- 10 ~100℃								
Installing	Downstream/Upstream									
Operating Method	Plunger Pilot									
Ambient and fluid	Air,Water,Oil,Steam (50CTS Bellow)									
Port size	G1/2	G3/4	G1	G1 1/4	G1 1/2	G2	G2 1/2	G3	G4	
Nominal Diameter mm	13	20	25	32	40	50	65	80	100	
Kv (m ³ /h)	4.2	8	19	27.5	42	55	90	115	200	
Pressure Range Mpa	0~1.6	0~1.6	0~1.6	0~1.6	0~1.6	0~1.6	0~1.6	0~1.6	0~1.6	
Min.Control Pressure Mpa	0.3	0.35	0.35	0.35	0.35	0.35	0.35	0.40	0.40	
Executor Dimension mm	40/50	50	50/63	63	63	63/80/90	80/90	100/125	125	

◆ Dimensions [mm]

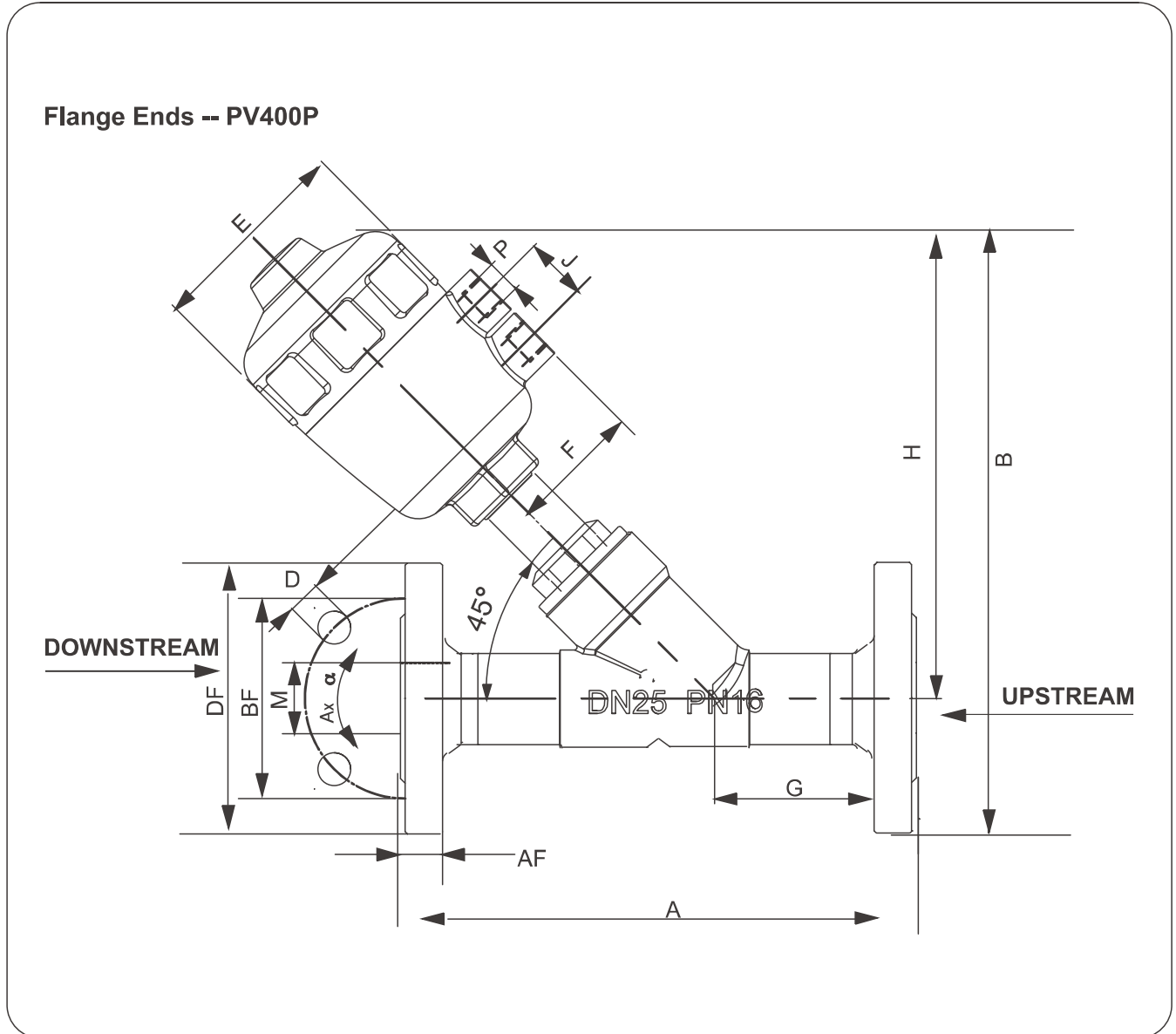

Port Size	DN (mm)	Actuator (mm)	A	B	D	E	F	G	H	J	M	P	AF	BF	DF
1/2"	DN15	50	130	165	14	64	44	24	115	24	15	12	15	65	95
3/4"	DN20	50	130	185	14	64	44	25	131	24	18	12	15	75	102
1"	DN25	50	140	195	14	64	44	30	138	24	25	12	15	85	114
		63	140	225	14	79.5	54	30	166	24	25	12	15	85	114
1-1/4"	DN32	63	150	240	18	79.5	54	30	172	24	30	12	17	100	133
1-1/2"	DN40	63	180	245	18	79.5	54	45	174	24	36	12	17	110	143
2"	DN50	63	195	275	18	79.5	54	50	193	24	47	12	17	125	158
		80	195	285	18	101	62	50	202	24	47	12	17	125	158
2-1/2"	DN65	80	230	300	18	101	62	55	209	24	68	12	18	145	180
3"	DN80	100	240	365	18	125	71	70	268	30	80	12	20	160	194
4"	DN100	125	265	420	18	158	93	90	314	30	100	12	20	180	215

Angle Seat Valve(Piston Valve) Series PV400 (Flange Ends)

◆ Dimensions [mm]

Flange Ends -- PV400S

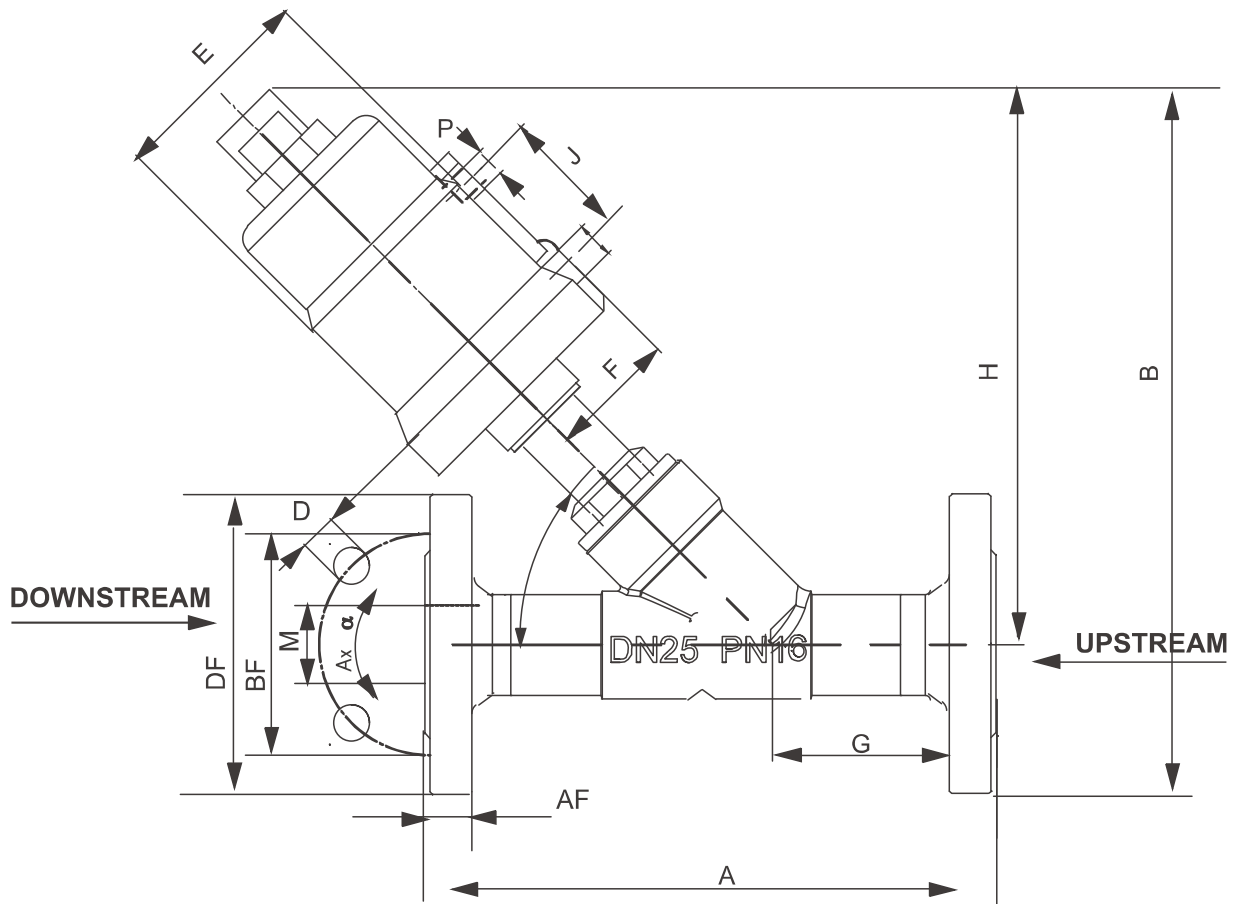

Port Size	DN (mm)	Actuator (mm)	A	B	D	E	F	G	H	J	M	P	AF	BF	DF
1/2"	DN15	50	130	190	14	56	35	24	142	38	15	G 1/8	15	65	95
3/4"	DN20	50	130	203	14	56	35	25	152	38	18	G 1/8	15	75	102
1"	DN25	50	140	215	14	56	35	30	155	38	25	G 1/8	15	85	114
		63	140	235	14	70	43	30	176	44	25	G 1/8	15	85	114
1-1/4"	DN32	63	150	245	18	70	43	30	177	44	30	G 1/8	17	100	133
1-1/2"	DN40	63	180	245	18	70	43	45	182	44	36	G 1/8	17	110	143
2"	DN50	63	195	274	18	70	43	50	196	44	47	G 1/8	17	125	158
		80/90	195	295	18	94	56	50	206	67	47	G 1/4	17	125	158
2-1/2"	DN65	80/90	230	305	18	94	56	55	215	67	68	G 1/4	18	145	180
3"	DN80	125	240	395	18	135	73	70	295	67	80	G 1/4	20	160	194
4"	DN100	125	265	445	18	135	73	90	332	67	100	G 1/4	20	180	215