



Male Threaded +Socket welded,
2/2-way Angle Seat Valve, Pneumatically Operated, for Medium up to +180°C,
Port connection DN 15-65;
Easy to install and maintain; Good replacement of Flange ends valve,
considerably cut the cost of the equipment applied to.

Angle Seat Valve(Piston Valve) Series PV200 (Male Threaded + Socket welded)

2/2-way Angle-Seat Valve Pneumatically Operated, for medium up to +180° C , male threaded port connection DN 15 - 65

- High flow rate;
- Long life cycle;
- NC and NO universal actuators with modular universal accessory program up to control heads;
- Deliverable with flow direction below or above seat
- Simple conversion of the circuit function.

◆ How to Order



PV200P025NCS



PV200S025NCS

PV200 P 015 NC S x 63mm

Symbol **Control function A**
(closed by spring force in rest position)

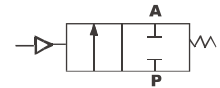

Control function B
(open in rest position)

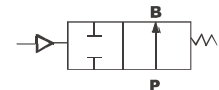

Control function I
(double-acting actuator)

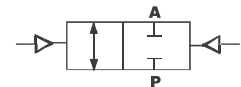

Acting type

S	Single acting	D	Double acting
---	---------------	---	---------------

Body Material

Blank	S.S 304	(standard)
4	S.S 316	
5	S.S 316L	

Control Function

NO	Normally open
NC	Normally closed(standard)

Nominal diameter

15	G1/2	20	G3/4
25	G 1	32	G1 1/4
40	G1 1/2	50	G 2
65	G2 1/2		

Actuator Material code

P	Plastic Actuator
S	S.S. Actuator
A	Aluminium Actuator

Model

PV200	200 series Angle Seat Valve
-------	-----------------------------

◆ Actuator Size

Port Size	Standard Actuator Size mm		
	PA	S.S.	AL
DN15	40,50	40,50	40,50
DN20	50,63,80	50,63,90	50,63,80
DN25	50,63,80	50,63,90	50,63,80
DN32	63,80	63,90	63,80
DN40	63,80	63,90	63,80
DN50	63,80	63,90	63,80
DN65	80,100	90,125	80,100

- ◆ PV200 Series Plunger Pilot angle seat valve is propelled by a piston actuator, either single acting or double acting. Actuators are made of three different materials, applicable to different working temperature:
2/2 Way stainless steel valve with big flow capacity
V type seals ensure reliable and effective sealing
Maintenance free, compatible with various accessories,
Direction indicating, stroke limiting or manual switching can be achieved conveniently.
Easy to install and maintain;
Good replacement of Flange ended valve, considerably cut the cost of the equipment applied to.

Angle Seat Valve(Piston Valve) Series PV200 (Male Threaded + Socket welded)



◆ Pressure Data Sheet

Control Function	Acting type	Flow Direction	Water Hammer	Application
Normally Closed	Single Acting	Upstream	Yes	For compressible medium (such as gas and steam) and liquid of comparatively low pressure
		Downstream	No	For anti water hammer pipeline, bears certain pressure difference
	Double Acting	Upstream	Yes	Reliable performance, bears pressure difference; valve closes automatically in case of an emergency.
		Downstream	No	For pipeline required of better anti water hammer, bears big pressure difference
Normally Open		Upstream	Yes	For pipeline where valve keeps open, double acting & normally open when silencer comes off.
		Downstream	No	For pipeline where valve keeps open, anti water hammer, double acting & normally open when silencer comes off

Water hammer (or, more generally, fluid hammer) is a pressure surge or wave caused when a fluid (usually a liquid but sometimes also a gas) in motion is forced to stop or change direction suddenly (momentum change). A water hammer commonly occurs when a valve closes suddenly at an end of a pipeline system, and a pressure wave propagates in the pipe. It is also called hydraulic shock.

This pressure wave can cause major problems, from noise and vibration to pipe collapse. It is possible to reduce the effects of the water hammer pulses with accumulators, expansion tanks, surge tanks, and other features.

Designed to close againstflow. Will not chatter or produce water hammer . Operates smoothly and quietly.

Port Size	DN (mm)	Actuator (mm)	Normally Closed				Normally Closed				Normally Open				Double Acting Assistant Pressure Mpa	Rest Position Pressure Mpa
			Upstream		Downstream		Upstream		Downstream		Upstream		Downstream			
			Press. Range Mpa	Control Press. Mpa	Press. Range Mpa	Control Press. Mpa	Press. Range Mpa	Control Press. Mpa	Press. Range Mpa	Control Press. Mpa	Press. Range Mpa	Control Press. Mpa	Press. Range Mpa	Control Press. Mpa		
1/2"	DN15	40	0~1.6	0.3~0.45	0~1.1				≥ 0.3					0.2~0.4	≥ 0.4	0~0.2
		50	0~1.6	0.3~0.35	0~1.4	0.45	0~1.6	0.3~0.35	0~1.6	≥ 0.3	0~1.6	0~1.6	0~1.6	0.2~0.4	≥ 0.4	0~0.1
3/4"	DN20	50	0~1.6	0.3~0.4	0~1.4	0.45	0~1.6	0.3~0.4	0~1.6	≥ 0.3	0~1.6	0~1.2	0~1.6	0.3~0.65	0.3~0.4	0~0.2
		63	0~1.6	0.3~0.38	0~1.4	0.45	0~1.6	0.3~0.38	0~1.6	0.3~0.5	0~1.6	0~1.4	0~1.6	0.35~0.7	0.3~0.35	0~0.35
		80	0~1.6	0.2~0.35	0~1.4	0.4	0~1.6	0.2~0.35	0~1.6	0.3~0.4	0~1.6	0~1.4	0~1.6	0.35~0.7	0.3~0.4	0~0.5
		90 SS	0~1.6	0.2~0.3	0~1.4	0.35	0~1.6	0.2~0.3	0~1.6	0.3~0.4	0~1.6	0~1.6	0~1.6	0.35~0.7	0.3~0.4	0~0.4
1"	DN25	50	0~1.6	0.3~0.45	0~0.75	0.45	0~1.6	0.3~0.45	0~1.3	0.3~0.6	0~1.6	0~0.3	0~1.3	0.3~0.6	0.3~0.4	0~0.35
		63	0~1.6	0.3~0.35	0~1.4	0.5	0~1.6	0.3~0.35	0~1.6	0.3~0.4	0~1.6	0~1.6	0~1.6	0.35~0.6	0.3~0.55	0~0.35
		80	0~1.6	0.2~0.3	0~1.4	0.45	0~1.6	0.2~0.3	0~1.6	0.3~0.4	0~1.6	0~1.6	0~1.6	0.35~0.6	0.35~0.55	0~0.5
		90 SS	0~1.6	0.2~0.25	0~1.4	0.4	0~1.6	0.2~0.25	0~1.6	0.2~0.3	0~1.6	0~1.6	0~1.6	0.35~0.6	0.35~0.55	0~0.4
1-1/4"	DN32	63	0~1.6	0.3~0.5	0~0.06	0.5	0~1.4	0.3~0.5	0~1.4	0.3~0.6	0~1.6	0~1.4	0~1.3	0.35~0.7	0.3~0.5	0~0.4
		80	0~1.6	0.2~0.45	0~1.4	0.6	0~1.6	0.2~0.45	0~1.6	0.3~0.5	0~1.6	0~1.6	0~1.6	0.35~0.7	0.3~0.55	0~0.5
		90 SS	0~1.6	0.2~0.35	0~1.6	0.65	0~1.6	0.2~0.35	0~1.6	0.2~0.4	0~1.6	0~1.6	0~1.6	0.35~0.7	0.3~0.55	0~0.4
1-1/2"	DN40	63	0~1.6	0.3~0.6	0~0.05	0.5	0~1.1	0.3~0.6	0~1.3	0.3~0.7	0~1.6	0~1.4	0~0.65	0.35~0.7	0.3~0.6	0~0.4
		80	0~1.6	0.3~0.55	0~1.4	0.6	0~1.6	0.3~0.55	0~1.6	0.3~0.6	0~1.6	0~1.6	0~1.6	0.35~0.7	0.3~0.7	0~0.5
		90 SS	0~1.6	0.2~0.35	0~1.6	0.65	0~1.6	0.2~0.35	0~1.6	0.2~0.6	0~1.6	0~1.6	0~1.6	0.35~0.7	0.3~0.7	0~0.5
2"	DN50	63	0~1.0	0.3~0.65	0~0.35	0.5	0~0.9	0.3~0.65	0~0.8	0.35~0.8	0~1.0	0~0.6	0~0.5	0.35~0.7	0.35~0.7	0~0.8
		80	0~1.6	0.3~0.55	0~0.9	0.65	0~1.6	0.3~0.55	0~1.6	0.3~0.7	0~1.6	0~1.0	0~0.6	0.35~0.7	0.35~0.7	0~0.5
		90 SS	0~1.6	0.3~0.5	0~1.1	0.65	0~1.6	0.3~0.5	0~1.6	0.3~0.6	0~1.6	0~1.0	0~1.0	0.35~0.7	0.35~0.7	0~0.4
		100	0~1.6	0.25~0.4	0~1.4	0.65	0~1.6	0.25~0.4	0~1.6	0.3~0.6	0~1.6	0~1.4	0~1.4	0.35~0.7	0.35~0.7	0~0.4
		125 SS	0~1.6	0.2~0.3	0~1.6	0.65	0~1.6	0.2~0.3	0~1.6	0.3~0.4	0~1.6	0~1.4	0~1.4	0.35~0.7	0.35~0.7	0~0.5
2-1/2"	DN65	80	0~1.6	0.3~0.65	0~0.5	0.65	0~1.6	0.3~0.65	0~1.1	0.3~0.7	0~1.6	0~0.5	0~0.75	0.3~0.65	0.35~0.7	0~0.5
		90 SS	0~1.6	0.2~0.6	0~0.7	0.65	0~1.6	0.2~0.6	0~1.6	0.3~0.7	0~1.6	0~1.0	0~1.4	0.3~0.6	0.35~0.7	0~0.4
		100	0~1.6	0.3~0.45	0~0.8	0.65	0~1.6	0.3~0.45	0~1.6	0.3~0.55	0~1.6	0~1.0	0~0.8	0.35~0.7	0.35~0.7	0~0.4
		125 SS	0~1.6	0.2~0.7	0~0.9	0.65	0~1.6	0.2~0.7	0~1.6	0.2~0.55	0~1.6	0~1.4	0~1.4	0.3~0.7	0.35~0.7	0~0.5

◆ Specifications

Model Specification	Normally Closed	P015NC	P020NC	P025NC	P032NC	P040NC	P050NC	P065NC
	Normally Open	P015NO	P020NO	P025NO	P032NO	P040NO	P050NO	P065NO
Material of Body / Actuator	S.S304 316 /PA							
Operating Method	Plunger Pilot							
Ambient and fluid	Air,Water,Oil,Steam (50CTS Bellow)							
Port size	G1/2	G3/4	G 1	G1 1/4	G1 1/2	G 2	G2 1/2	
Nominal Diameter mm	13	18	24	31	35	45	61	
Kv (m ³ /h)	4.2	9	19	33	42	59	90	
Model Specification	Normally Closed	S015NC	S020NC	S025NC	S032NC	S040NC	S050NC	S065NC
	Normally Open	S015NO	S020NO	S025NO	S032NO	S040NO	S050NO	S065NO
Material of Body / Actuator	S.S304 316 /PA							
Seat seal	PTFE/FPM							
Stem seal	PTFE/FPM							
Piston Seal	PTFE/FPM/NBR							
Temperature of Medium	PTFE	- 10 ~200°C						
	FPM	- 10 ~150°C						
Installing	Downstream/Upstream							

Angle Seat Valve(Piston Valve) Series PV200 (Male Threaded + Socket welded)

◆ Dimensions [mm]

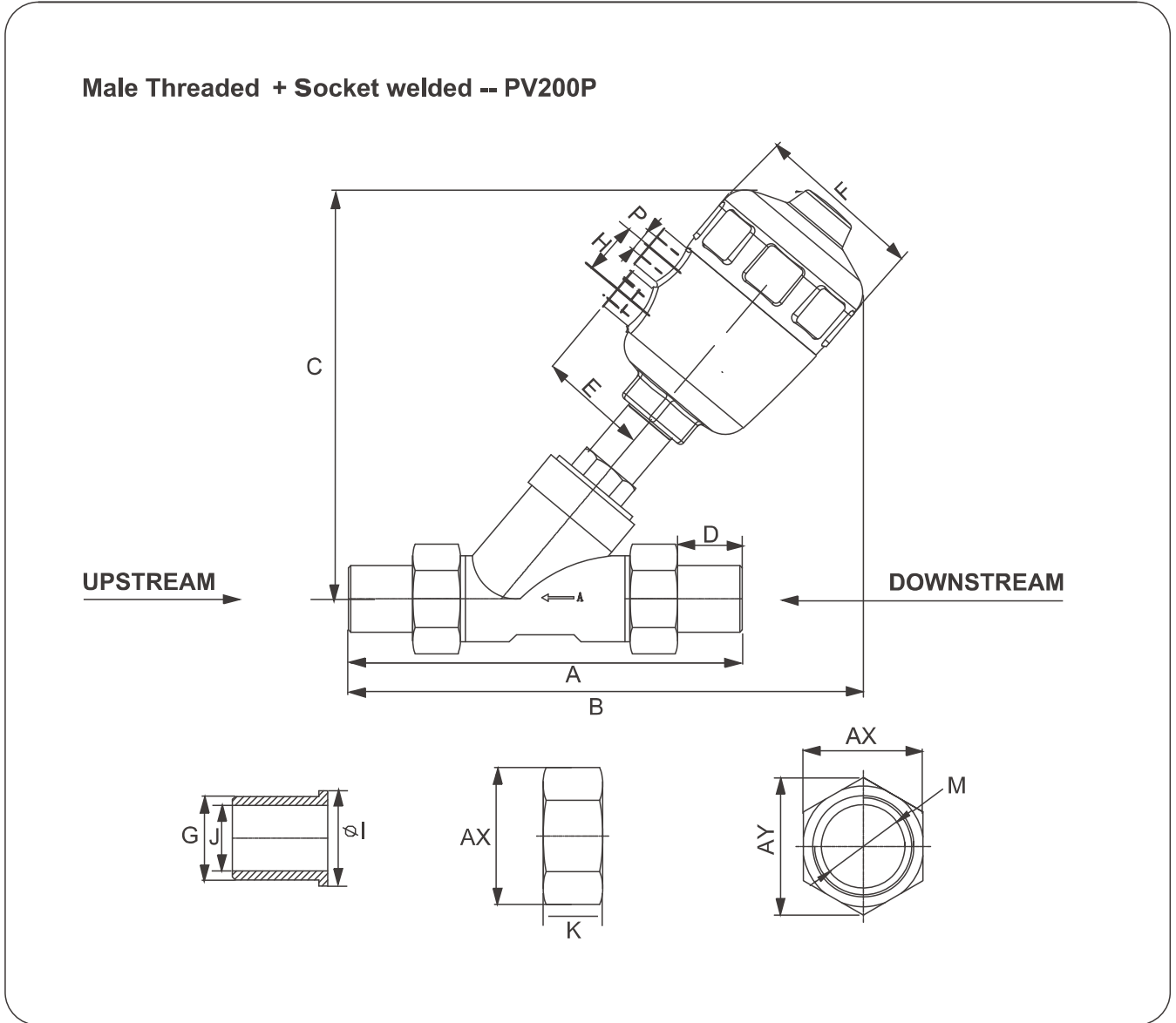

Port Size	DN (mm)	Actuator (mm)	A	B	C	D	E	F	G	H	J	K	M	P	AX	AY
1/2"	DN15	40	135	184	115	22	30	53	18	20	12.5	17	19	G 1/8	27	31
		50	135	190	115	22	44	64	18	24	12.5	17	19	G 1/4	27	31
3/4"	DN20	50	150	200	131	25	44	64	22	24	18	19	22.3	G 1/4	31	35
1"	DN25	50	170	205	138	29	44	64	28	24	22.5	20.5	28.3	G 1/4	40	45.5
		63	170	247	166	29	54	79.5	28	24	22.5	20.5	28.3	G 1/4	40	45.5
1-1/4"	DN32	63	185	257	172	29	54	79.5	35.5	24	30	21	35.5	G 1/4	49	56
1-1/2"	40	63	208	263	174	31	54	79.5	43.5	24	38	23	43.5	G 1/4	54	62
2"	50	63	236	288	193	35.5	54	79.5	54.5	24	47.5	24	55	G 1/4	54	62
		80	236	299	202	35.5	62	101	54.5	24	47.5	24	55	G 1/4	69	79
2-1/2"	65	80	250	312	209	32	62	101	72.5	24	62.5	28.5	73	G 1/4	90	101

Angle Seat Valve(Piston Valve) Series PV200 (Male Threaded + Socket welded)

◆ Dimension [mm]

Male Threaded + Socket welded -- PV200S

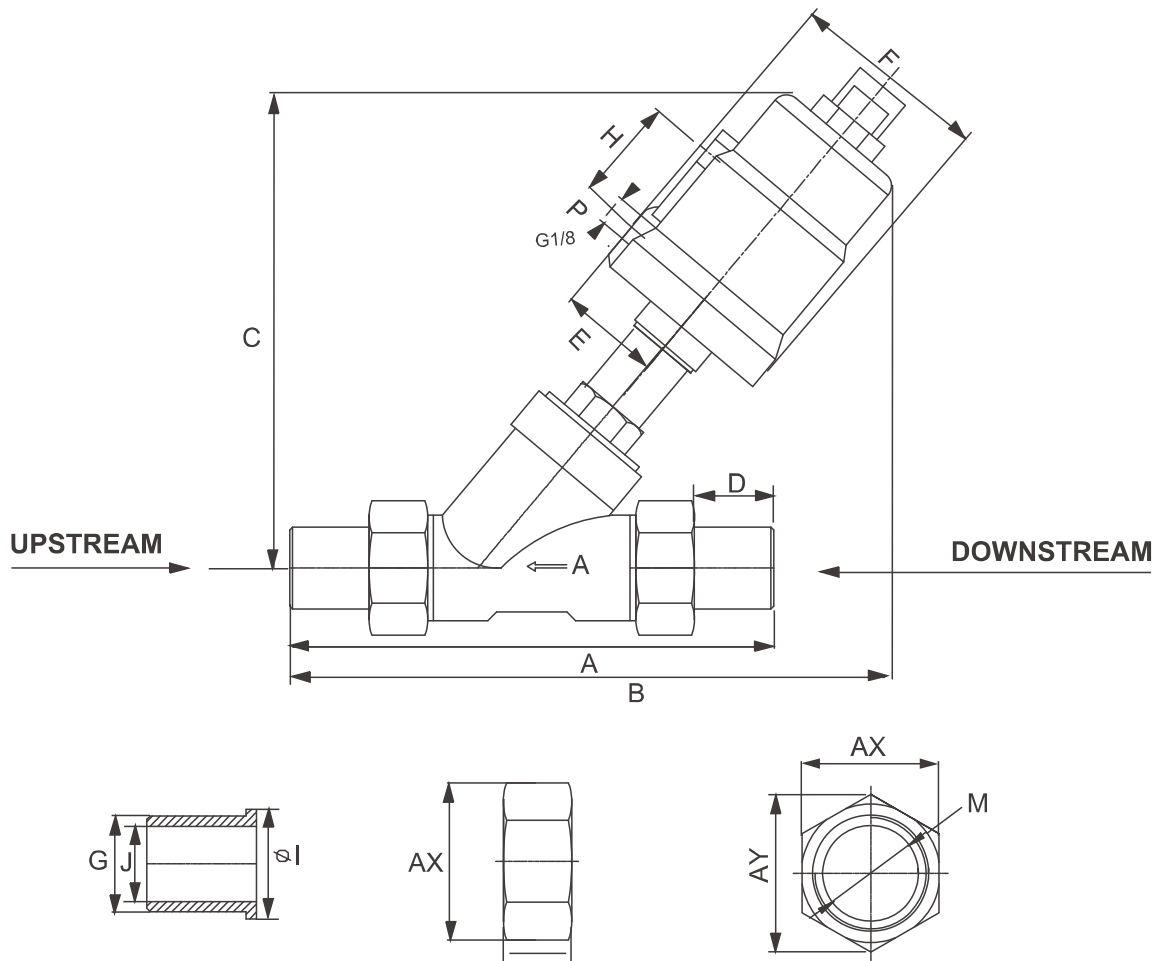

Port Size	DN (mm)	Actuator (mm)	A	B	C	D	E	F	G	H	J	K	M	P	AX	AY
1/2"	DN15	40	135	179	113	22	28	53	18	38	12.5	17	19	G 1/8	27	31
		50	135	194	142	22	35	56	18	38	12.5	17	19	G 1/8	27	31
3/4"	DN20	50	150	224	152	25	35	56	22	38	18	19	22.3	G 1/8	31	35
1"	DN25	50	170	236	155	29	35	56	28	38	22.5	20.5	28.3	G 1/8	40	45.5
		63	170	246	176	29	43	70	28	44	22.5	20.5	28.3	G 1/8	40	45.5
1-1/4"	DN32	63	185	251	177	29	43	70	35.5	44	30	21	35.5	G 1/8	49	56
1-1/2"	40	63	208	256	182	31	43	70	43.5	44	38	23	43.5	G 1/8	54	62
2"	50	63	236	284	196	35.5	43	70	54.5	44	47.5	24	55	G 1/8	54	62
		90	236	303	206	35.5	56	94	54.5	67	47.5	24	55	G 1/4	69	79
2-1/2"	65	90	250	322	215	32	56	94	72.5	67	62.5	28.5	73	G 1/4	90	101