



Threaded Ends ,
2/2-way stainless steel Angle Seat Valve with big flow capacity, Pneumatically Operated,
Excellent seat tightness due to PTFE soft sealing ,
for Medium up to +180°C, Port connection DN 10-80

Angle Seat Valve(Piston Valve) Series PV100 (Threaded Ends)

2/2-way Angle-Seat Valve Pneumatically Operated, for medium up to +180° C, threaded port connection DN 10-80

- High flow rate;
- Long life cycle;
- NC and NO universal actuators with modular universal accessory program up to control heads;
- Deliverable with flow direction below or above seat
- Simple conversion of the circuit function.

◆ How to Order



PV100S025NCS



PV100P040NCS

PV100 P 015 NC S x 63mm

Acting type

S	Single acting	D	Double acting
---	---------------	---	---------------

Body Material

Blank	S.S 304 (standard)
4	S.S 316
5	S.S 316L

Control Function

NO	Normally open
NC	Normally closed (standard)

Nominal diameter

10	G3/8	15	G1/2
20	G3/4	25	G1
32	G1 1/4	40	G1 1/2
50	G2	65	G2 1/2
80	G3		

Actuator Material code

P	PA Actuator
S	S.S. Actuator
A	Aluminium Actuator

Model

PV100	100 series Angle Seat Valve
-------	-----------------------------

Symbol

Control function A
(closed by spring force
in rest position)

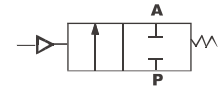

Control function B
(open in rest position)

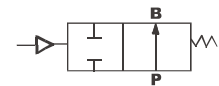

Control function I
(double-acting actuator)

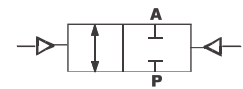

◆ Actuator Size

Port Size	Standard Actuator Size mm		
	PA	S.S.	AL
DN10	40,50	40,50	40,50
DN15	40,50	40,50	40,50
DN20	50,63,80	50,63,90	50,63,80
DN25	50,63,80	50,63,90	50,63,80
DN32	63,80	63,90	63,80
DN40	63,80	63,90	63,80
DN50	63,80	63,90	63,80
DN65	80,100	90,125	80,100
DN80	100	125	100
DN100	125	125	125

- ◆ PV100 Series Plunger Pilot angle seat valve is propelled by piston actuator, either single acting or double acting. Actuators are made of three different materials, applicable to different working temperature:
2/2 Way stainless steel valve with big flow capacity
V type seals ensure reliable and effective sealing
Maintenance free, compatible with various accessories,
Direction indicating, stroke limiting or manual switching can be achieved conveniently.

Angle Seat Valve(Piston Valve) Series PV100 (Threaded Ends)



◆ Pressure Data Sheet

Control Function	Acting type	Flow Direction	Water Hammer	Application
Normally Closed	Single Acting	Upstream	Yes	For compressible medium (such as gas and steam) and liquid of comparatively low pressure
		Downstream	No	For anti water hammer pipeline, bears certain pressure difference
	Double Acting	Upstream	Yes	Reliable performance, bears pressure difference; valve closes automatically in case of an emergency.
		Downstream	No	For pipeline required of better anti water hammer, bears big pressure difference
Normally Open		Upstream	Yes	For pipeline where valve keeps open, double acting & normally open when silencer comes off.
		Downstream	No	For pipeline where valve keeps open, anti water hammer, double acting & normally open when silencer comes off

Water hammer (or, more generally, fluid hammer) is a pressure surge or wave caused when a fluid (usually a liquid but sometimes also a gas) in motion is forced to stop or change direction suddenly (momentum change). A water hammer commonly occurs when a valve closes suddenly at an end of a pipeline system, and a pressure wave propagates in the pipe. It is also called hydraulic shock.

This pressure wave can cause major problems, from noise and vibration to pipe collapse. It is possible to reduce the effects of the water hammer pulses with accumulators, expansion tanks, surge tanks, and other features.

Designed to close against the flow. Will not chatter or produce water hammer . Operates smoothly and quietly.

Port Size	DN (mm)	Actuator (mm)	Single Acting Normally Closed				Double Acting Normally Closed				Normally Open				Double Acting Assistant Pressure Mpa	Rest Position Pressure Mpa
			Upstream		Downstream		Upstream		Downstream		Upstream		Downstream			
			Press. Range Mpa	Control Press. Mpa	Press. Range Mpa	Control Press. Mpa	Press. Range Mpa	Control Press. Mpa	Press. Range Mpa	Control Press. Mpa	Press. Range Mpa	Control Press. Mpa	Press. Range Mpa	Control Press. Mpa		
3/8"	DN10	40	0~1.6	0.3~0.45	0~1.1	0.3	0~1.6	0.3~0.45	0~1.6	≥ 0.3	0~1.6	0~1.6	0~1.6	0.2~0.4	≥ 0.4	0~0.2
		50	0~1.6	0.3~0.35	0~1.4	0.45	0~1.6	0.3~0.35	0~1.6	≥ 0.3	0~1.6	0~1.6	0~1.6	0.2~0.4	≥ 0.3	0~0.1
1/2"	DN15	40	0~1.6	0.3~0.45	0~1.1	0.3	0~1.6	0.3~0.45	0~1.6	≥ 0.3	0~1.6	0~1.6	0~1.6	0.2~0.4	≥ 0.4	0~0.2
		50	0~1.6	0.3~0.35	0~1.4	0.45	0~1.6	0.3~0.35	0~1.6	≥ 0.3	0~1.6	0~1.6	0~1.6	0.2~0.4	≥ 0.4	0~0.1
3/4"	DN20	50	0~1.6	0.3~0.4	0~1.4	0.45	0~1.6	0.3~0.4	0~1.6	≥ 0.3	0~1.6	0~1.2	0~1.6	0.3~0.65	0.3~0.4	0~0.2
		63	0~1.6	0.3~0.38	0~1.4	0.45	0~1.6	0.3~0.38	0~1.6	0.3~0.5	0~1.6	0~1.4	0~1.6	0.35~0.7	0.3~0.35	0~0.35
		80	0~1.6	0.2~0.35	0~1.4	0.4	0~1.6	0.2~0.35	0~1.6	0.3~0.4	0~1.6	0~1.4	0~1.6	0.35~0.7	0.3~0.4	0~0.5
		90 SS	0~1.6	0.2~0.3	0~1.4	0.35	0~1.6	0.2~0.3	0~1.6	0.3~0.4	0~1.6	0~1.6	0~1.6	0.35~0.7	0.3~0.4	0~0.4
1"	DN25	50	0~1.6	0.3~0.45	0~0.75	0.45	0~1.6	0.3~0.45	0~1.3	0.3~0.6	0~1.6	0~0.3	0~1.3	0.3~0.6	0.3~0.4	0~0.35
		63	0~1.6	0.3~0.35	0~1.4	0.5	0~1.6	0.3~0.35	0~1.6	0.3~0.4	0~1.6	0~1.6	0~1.6	0.35~0.6	0.3~0.55	0~0.35
		80	0~1.6	0.2~0.3	0~1.4	0.45	0~1.6	0.2~0.3	0~1.6	0.3~0.4	0~1.6	0~1.6	0~1.6	0.35~0.6	0.35~0.55	0~0.5
		90 SS	0~1.6	0.2~0.25	0~1.4	0.4	0~1.6	0.2~0.25	0~1.6	0.2~0.3	0~1.6	0~1.6	0~1.6	0.35~0.6	0.35~0.55	0~0.4
1-1/4"	DN32	63	0~1.6	0.3~0.5	0~0.06	0.5	0~1.4	0.3~0.5	0~1.4	0.3~0.6	0~1.6	0~1.4	0~1.3	0.35~0.7	0.3~0.5	0~0.4
		80	0~1.6	0.2~0.45	0~1.4	0.6	0~1.6	0.2~0.45	0~1.6	0.3~0.5	0~1.6	0~1.6	0~1.6	0.35~0.7	0.3~0.55	0~0.5
		90 SS	0~1.6	0.2~0.35	0~1.6	0.65	0~1.6	0.2~0.35	0~1.6	0.2~0.4	0~1.6	0~1.6	0~1.6	0.35~0.7	0.3~0.55	0~0.4
1-1/2"	DN40	63	0~1.6	0.3~0.6	0~0.05	0.5	0~1.1	0.3~0.6	0~1.3	0.3~0.7	0~1.6	0~1.4	0~0.6	0.35~0.7	0.3~0.6	0~0.4
		80	0~1.6	0.3~0.55	0~1.4	0.6	0~1.6	0.3~0.55	0~1.6	0.3~0.6	0~1.6	0~1.6	0~1.6	0.35~0.7	0.3~0.7	0~0.5
		90 SS	0~1.6	0.2~0.35	0~1.6	0.65	0~1.6	0.2~0.35	0~1.6	0.2~0.6	0~1.6	0~1.6	0~1.6	0.35~0.7	0.3~0.7	0~0.5
2"	DN50	63	0~1.0	0.3~0.65	0~0.35	0.5	0~0.9	0.3~0.65	0~0.8	0.35~0.8	0~1.0	0~0.6	0~0.5	0.35~0.7	0.35~0.7	0~0.8
		80	0~1.6	0.3~0.55	0~0.9	0.65	0~1.6	0.3~0.55	0~1.6	0.3~0.7	0~1.6	0~1.0	0~0.6	0.35~0.7	0.35~0.7	0~0.5
		90 SS	0~1.6	0.3~0.5	0~1.1	0.65	0~1.6	0.3~0.5	0~1.6	0.3~0.6	0~1.6	0~1.0	0~1.2	0.35~0.7	0.35~0.7	0~0.4
		100	0~1.6	0.25~0.4	0~1.4	0.65	0~1.6	0.25~0.4	0~1.6	0.3~0.6	0~1.6	0~1.4	0~1.4	0.35~0.7	0.35~0.7	0~0.4
		125 SS	0~1.6	0.2~0.3	0~1.6	0.65	0~1.6	0.2~0.3	0~1.6	0.3~0.4	0~1.6	0~1.4	0~1.4	0.35~0.7	0.35~0.7	0~0.5
2-1/2"	DN65	80	0~1.6	0.3~0.65	0~0.5	0.65	0~1.6	0.3~0.65	0~1.1	0.3~0.7	0~1.6	0~0.5	0~0.75	0.3~0.65	0.35~0.7	0~0.5
		90 SS	0~1.6	0.2~0.6	0~0.7	0.65	0~1.6	0.2~0.6	0~1.6	0.3~0.7	0~1.6	0~1.0	0~1.4	0.3~0.6	0.35~0.7	0~0.4
		100	0~1.6	0.3~0.45	0~0.8	0.65	0~1.6	0.3~0.45	0~1.6	0.3~0.55	0~1.6	0~1.0	0~0.8	0.35~0.7	0.35~0.7	0~0.4
		125 SS	0~1.6	0.2~0.7	0~0.9	0.65	0~1.6	0.2~0.7	0~1.6	0.2~0.55	0~1.6	0~1.4	0~1.4	0.3~0.7	0.35~0.7	0~0.5
3"	DN80	100	0~1.6	0.35~0.6	0~0.5	0.65	0~1.6	0.35~0.6	0~1.6	0.3~0.55	0~1.6	0~0.6	0~0.75	0.35~0.7	0.35~0.7	0~0.4
		125 SS	0~1.6	0.2~0.7	0~0.6	0.65	0~1.6	0.2~0.7	0~1.6	0.3~0.65	0~1.6	0~0.7	0~1.2	0.35~0.7	0.35~0.7	0~0.5

◆ Specifications

Model Specification	Normally Closed	P010NC	P015NC	P020NC	P025NC	P032NC	P040NC	P050NC	P065NC	P080NC
	Normally Open	P010NO	P015NO	P020NO	P025NO	P032NO	P040NO	P050NO	P065NO	P080NO
Material of Body / Actuator	S,S304 316 /PA									
Operating Method	Plunger Pilot									
Ambient and fluid	Air,Water,Oil,Steam (50CTS Bellow)									
Port size	G3/8	G1/2	G3/4	G 1	G1 1/4	G1 1/2	G 2	G2 1/2	G 3	
Nominal Diameter (mm)	13	13	18	24	31	35	45	61	80	
Kv (m ³ /h)	3.7	4.2	9	19	33	42	59	90	135	
Model Specification	Normally Closed	S010NC	S015NC	S020NC	S025NC	S032NC	S040NC	S050NC	S065NC	S080NC
	Normally Open	S010NO	S015NO	S020NO	S025NO	S032NO	S040NO	S050NO	S065NO	S080NO
Material of Body / Actuator	S,S304 316 /PA									
Seat seal	PTFE/FPM									
Stem seal	PTFE/FPM									
Piston Seal	PTFE/FPM/NBR									
Temperature of Medium	PTFE	- 10 ~200°C								
	FPM	- 10 ~150°C								
Installing	Downstream/Upsteam									

Angle Seat Valve(Piston Valve) Series PV100 (Threaded Ends)

◆ Dimensions [mm]

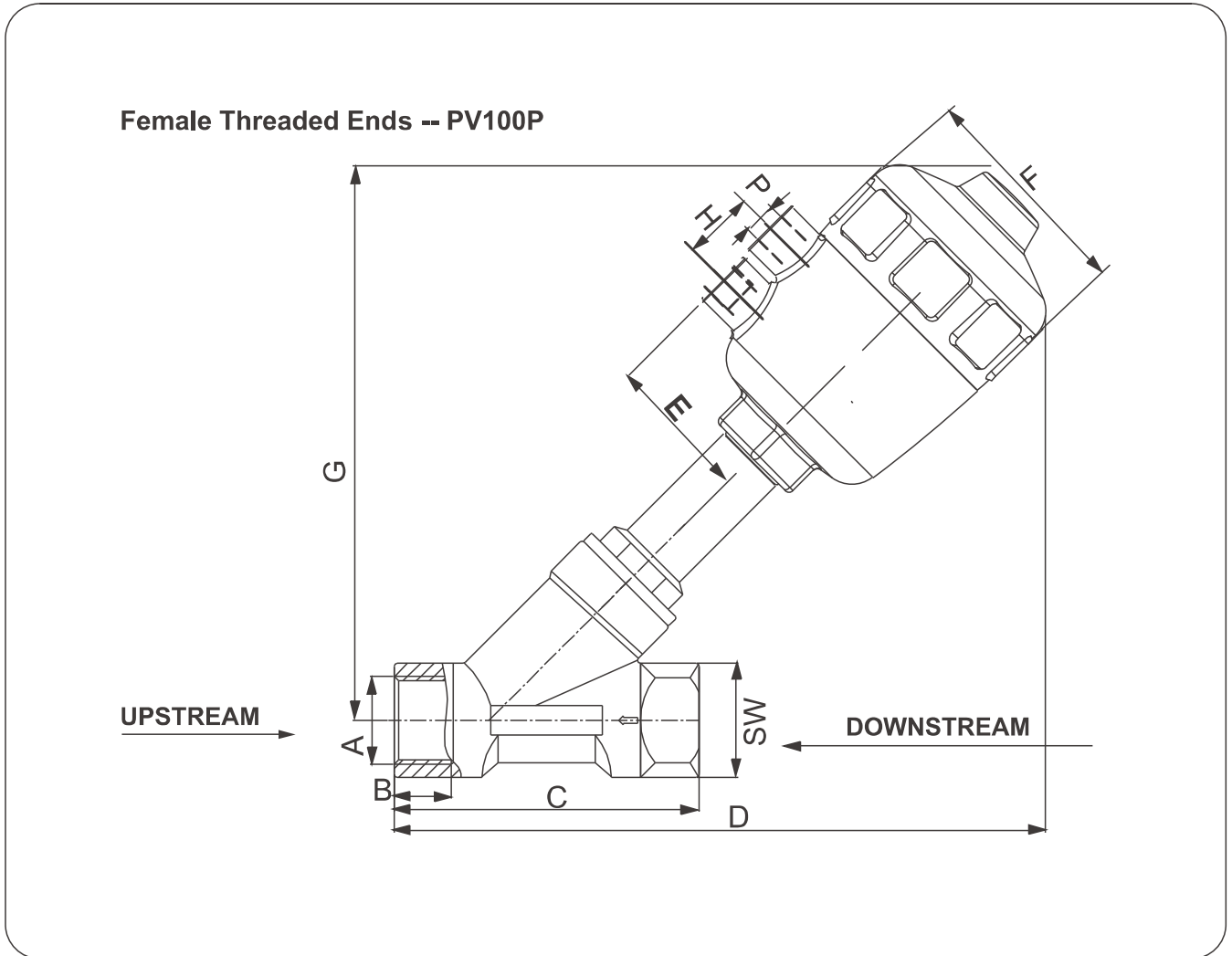

Port Size	DN (mm)	Actuator (mm)	A	B	C	D	E	F	G	H	P	SW
3/8"	DN10	40	G3/8	12	65	142	30	53	85	20	G1/8	25
		50	G3/8	12	65	145	44	64	100	24	G1/4	25
1/2"	DN15	40	G1/2	14	76	162	30	53	115	20	G1/8	28
		50	G1/2	14	76	168	44	64	115	24	G1/4	28
3/4"	DN20	50	G3/4	16	92	175	44	64	131	24	G1/4	32
		63	G3/4									
1"	DN25	50	G1	21	103	186	44	64	138	24	G1/4	39
		63	G1	21	103	218	54	79.5	166	24	G1/4	39
1-1/4	DN32	63	G1-1/4	19	112	228	54	79.5	172	24	G1/4	49
1-1/2	DN40	63	G1-1/2	21	129	232	54	79.5	174	24	G1/4	56
2"	DN50	63	G2	27	143	252	54	79.5	193	24	G1/4	68
		80	G2	27	143	263	62	101	202	24	G1/4	68
2-1/2"	DN65	80	G2-1/2	28	186	280	62	101	209	24	G1/4	84
3"	DN80	100	G3	34	218	355	71	125	268	30	G1/4	101

Angle Seat Valve(Piston Valve) Series PV100 (Threaded Ends)

◆ Dimensions [mm]

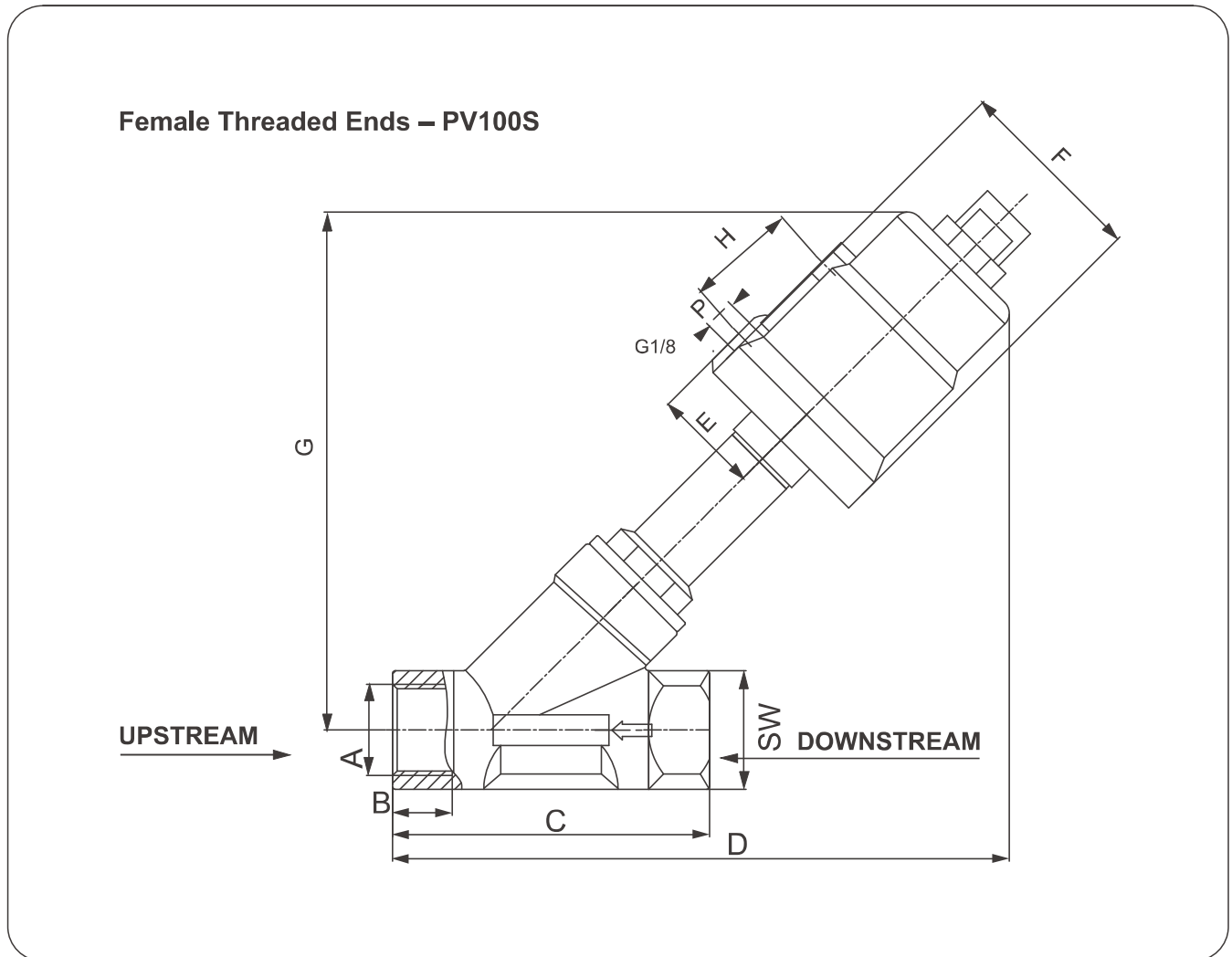

Port Size	DN (mm)	Actuator (mm)	A	B	C	D	E	F	G	H	P	SW
3/8"	DN10	40	G3/8	12	65	144	28	53	105	38	G1/8	25
		50	G3/8	12	65	//	35	56	//	38	G1/8	25
1/2"	DN15	40	G1/2	14	76	157	28	53	113	38	G1/8	28
		50	G1/2	14	76	182	35	56	142	38	G1/8	28
3/4"	DN20	50	G3/4	16	92	189	35	56	152	38	G1/8	32
		63	G3/4	16	92		43	70		44	G1/8	32
1"	DN25	50	G1	21	103	207	35	56	155	38	G1/8	39
		63	G1	21	103	217	43	70	176	44	G1/8	39
1-1/4	DN32	63	G1-1/4	19	112	222	43	70	177	44	G1/8	49
1-1/2	DN40	63	G1-1/2	21	129	225	43	70	182	44	G1/8	56
2"	DN50	63	G2	27	143	249	43	70	196	44	G1/8	68
		90	G2	27	143	268	56	94	206	67	G1/4	68
2-1/2"	DN65	90	G2-1/2	28	186	290	56	94	215	67	G1/4	84
3"	DN80	125	G3	34	218	335	73	135	295	67	G1/4	101